

Braided Expansion Joints



Scan this QR Code



Ayvaz U-Flex and V-Flex assemblies provide highly flexible and reliable connection features for fire protection lines, seismic security areas, dilatation points and industrial applications. These assemblies are used to absorb the movements caused by the potential break downs and depressions especially where the seismic movements may cause hazardous results.

Ayvaz U-Flex and V-Flex assemblies that are manufactured with FM certificate prevent the structural deformations such as cracks and break downs of rigid connections by the required flexibility they provide and offer easy, safe and reliable installation features for the users.

DESIGN

Ayvaz U-Flex and V-Flex assemblies are consisted of the parallel corrugated metal hose with braiding and Carbon Steel connection and direction parts likewise turns and elbows at various angles. Flexible metal hose provides high movement capacity in all directions to the assemblies and the braiding increases the pressure resistance accordingly

Structure

Bellow Material	Stainless Steel AISI 316L / AISI 321
Braiding Material	Stainless Steel AISI 304
Connection Types	Flange, Welded End, Grooved
Flange Material	Carbon Steel St. 37.2 , the material can be customized on request
Elbow and Turn Material	Carbon Steel St. 37.2 , the material can be customized on request

Operation Conditions

Operating Temperature	-80°C/+600°C
Operating Pressure	16 bar

Nominal Diameters DN15 (1/2") - DN250 (10")

BRAIDED LOOP JOINTS

U-Flex, Braided Loop Joints



Available Types (Standard Versions)

Name	Movement Amount All Plates	Design Pressure	Definition
U-Flex	50mm-100mm	175 psi	U-type, 3D braided Loop-joint, Welded End
U-Flex	50mm-100mm	175 psi	U-type, 3D braided Loop-joint, Flanged
U-Flex	50mm-100mm	175 psi	U-type, 3D braided Loop-joint, Grooved End

* Special designed, Braided Loop Joints with customized features are available on request.

** Subject to technical alterations and deviations resulting from the manufacturing process without giving any notification.

U-type, 3D braided Loop-joint, Welded End

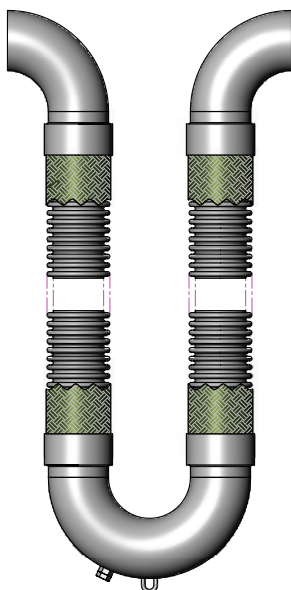
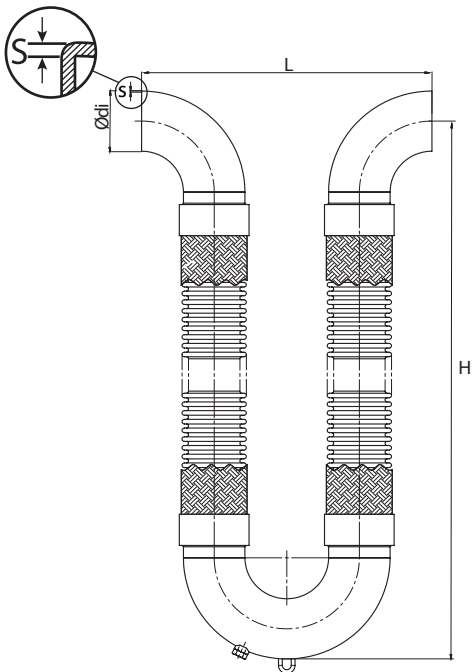

DN	Ødi	S	Movement in all directions ±mm	L	H	Code
DN15	21,3	2,6	±50	150	325	702.080.301.010
			±100	225	425	702.080.301.015
DN20	26,9	2,6	±50	131,25	325	702.080.301.020
			±100	231,25	450	702.080.301.025
DN25	33,7	2,6	±50	152	380	702.080.301.030
			±100	254	510	702.080.301.035
DN32	42,4	2,6	±50	190	410	702.080.301.040
			±100	273	535	702.080.301.045
DN40	48,3	2,6	±50	228	435	702.080.301.050
			±100	292	585	702.080.301.055
DN50	60,3	2,9	±50	304	485	702.080.301.060
			±100	356	635	702.080.301.065
DN65	76,1	2,9	±50	380	535	702.080.301.070
			±100	456	762	702.080.301.075
DN80	88,9	3,2	±50	456	585	702.080.301.080
			±100	608	890	702.080.301.085
DN100	114,3	3,6	±50	608	715	702.080.301.090
			±100	760	1020	702.080.301.095
DN125	139,7	4	±50	760	815	702.080.301.100
			±100	920	1170	702.080.301.105
DN150	168,3	4,5	±50	920	940	702.080.301.110
			±100	1220	1475	702.080.301.115
DN200	219,1	6,3	±50	1220	1220	702.080.301.120
			±100	1120	1375	702.080.301.125
DN250	273	7,1	±50	1524	1400	702.080.301.130
			±100	1524	1702	702.080.301.135

All the dimensions in the table are given in "mm".

U-type, 3D braided Loop-joint, Flanged

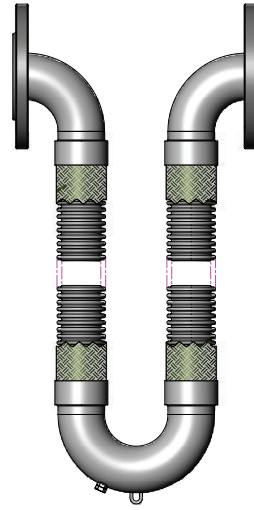
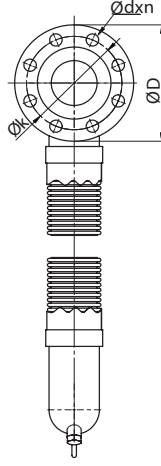
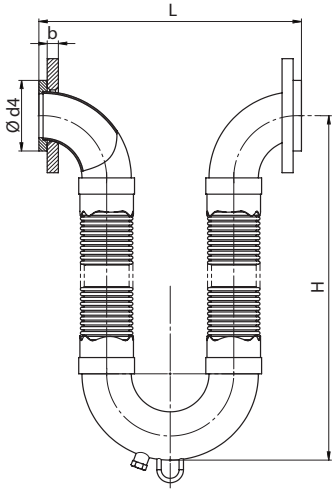

DN	Flange (DIN EN 1092/1) PN 16					Movement in all directions ±mm	L mm	H mm	Code
	ØD mm	Øk mm	b mm	Ødxn	Ød4 mm				
DN15	95	65	14	Ø14x4	45	±50	165	330	702.080.303.010
						±100	240	435	702.080.303.015
DN20	105	75	16	Ø14x4	58	±50	145	330	702.080.303.020
						±100	245	460	702.080.303.025
DN25	115	85	16	Ø14x4	68	±50	222	380	702.080.303.030
						±100	324	510	702.080.303.035
DN32	140	100	18	Ø18x4	78	±50	260	410	702.080.303.040
						±100	343	535	702.080.303.045
DN40	150	115	18	Ø18x4	88	±50	300	435	702.080.303.050
						±100	362	585	702.080.303.055
DN50	165	125	20	Ø18x4	102	±50	375	485	702.080.303.060
						±100	426	635	702.080.303.065
DN65	185	145	20	Ø18x4	122	±50	450	535	702.080.303.070
						±100	450	715	702.080.303.075
DN80	200	160	20	Ø18x8	138	±50	536	585	702.080.303.080
						±100	536	765	702.080.303.085
DN100	220	180	22	Ø18x8	158	±50	680	715	702.080.303.090
						±100	680	890	702.080.303.095
DN125	250	210	22	Ø18x8	188	±50	832	815	702.080.303.100
						±100	832	1020	702.080.303.105
DN150	285	240	24	Ø23x8	212	±50	992	940	702.080.303.110
						±100	992	1170	702.080.303.115
DN200	340	295	26	Ø23x12	268	±50	1292	1220	702.080.303.120
						±100	1292	1475	702.080.303.125
DN250	405	355	29	Ø27x12	320	±50	1600	1400	702.080.303.130
						±100	1600	1702	702.080.303.135

All the dimensions in the table are given in "mm".
Other flange types made according to different standards (ANSI, BS, UNI) are also available.

BRAIDED LOOP JOINTS

V-Flex, Braided Loop Joints



Available Types (Standard Versions)

Name	Movement Amount All Plates	Design Pressure	Definition
V-Flex	100mm	175 psi	U-type, 3D braided Loop-joint, Welded End
V-Flex	100mm	175 psi	U-type, 3D braided Loop-joint, Flanged
V-Flex	100mm	175 psi	U-type, 3D braided Loop-joint, Grooved End

* Special designed, Braided Loop Joints with customized features are available on request.

** Subject to technical alterations and deviations resulting from the manufacturing process without giving any notification.

V-type, 3D braided Loop-joint, Welded End

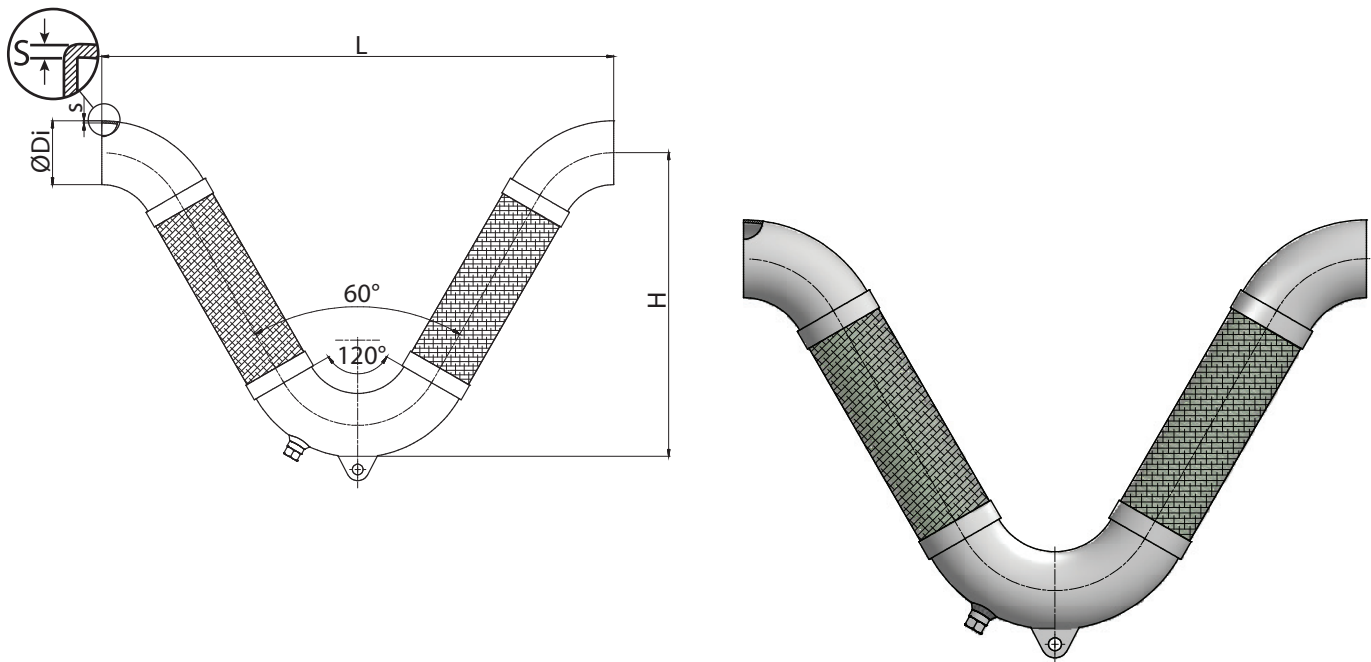

DN	ØDi	s	H	L	Movement in all directions ±mm	Code
DN15	21,3	2,6	330	505	±100	702.090.301.015
DN20	26,9	2,6	330	505	±100	702.090.301.025
DN25	33,7	2,6	505	330	±100	702.090.301.035
DN32	42,4	2,6	505	330	±100	702.090.301.045
DN40	48,3	2,6	505	330	±100	702.090.301.055
DN50	60,3	2,9	515	350	±100	702.090.301.065
DN65	76,1	2,9	620	415	±100	702.090.301.075
DN80	88,9	3,2	720	470	±100	702.090.301.085
DN100	114,3	3,6	880	545	±100	702.090.301.095
DN125	139,7	4	1070	650	±100	702.090.301.105
DN150	168,3	4,5	1255	750	±100	702.090.301.115
DN200	219,1	6,3	1520	850	±100	702.090.301.125
DN250	273	7,1	1970	1080	±100	702.090.301.135

All the dimensions in the table are given in "mm".

V-type, 3D braided Loop-joint, Flanged

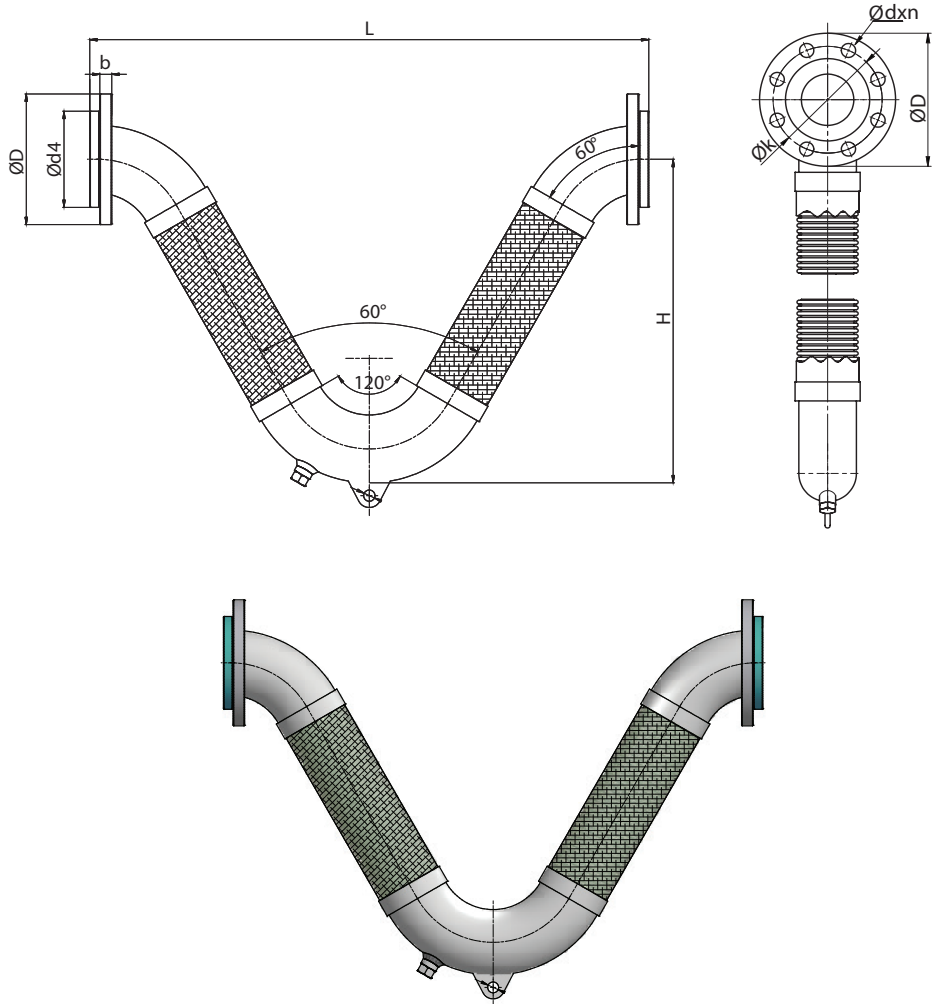

DN	Flange (DIN EN 1092/1) PN 16					H mm	L mm	Movement in all directions ±mm	Code
	ØD mm	Øk mm	b mm	Ødxn	Ød4 mm				
DN25	115	85	16	Ø14x4	68	330	530	±50	702.090.303.035
DN32	140	100	18	Ø18x4	78	330	530	±50	702.090.303.045
DN40	150	115	18	Ø18x4	88	310	530	±50	702.090.303.055
DN50	165	125	20	Ø18x4	102	350	570	±50	702.090.303.065
DN65	185	145	20	Ø18x4	122	415	675	±50	702.090.303.075
DN80	200	160	20	Ø18x8	138	470	785	±50	702.090.303.085
DN100	220	180	22	Ø18x8	158	545	945	±50	702.090.303.095
DN125	250	210	22	Ø18x8	188	650	1140	±50	702.090.303.105
DN150	285	240	24	Ø23x8	212	750	1325	±50	702.090.303.115
DN200	340	295	26	Ø23x12	268	850	1600	±50	702.090.303.125
DN250	405	355	29	Ø27x12	320	1080	2045	±50	702.090.303.135

All the dimensions in the table are given in "mm".
Other flange types made according to different standarts (ANSI, BS, UNI) are also available.